

< HV MOSFET MODULE >

# FMF800DC-66BEW

HIGH POWER SWITCHING USE

INSULATED TYPE

2<sup>nd</sup> gen. HV MOSFET (High Voltage Metal Oxide Semiconductor Field Effect Transistor) Modules

## FMF800DC-66BEW



- $I_D$ .....800A
- $V_{DSX}$ .....3300V
- 2-element in a Pack
- Insulated Type
- SiC SBD embedded MOSFET

## APPLICATION

Traction drives, High Reliability Converters / Inverters, DC choppers

## OUTLINE DRAWING & CIRCUIT DIAGRAM

Dimensions in mm

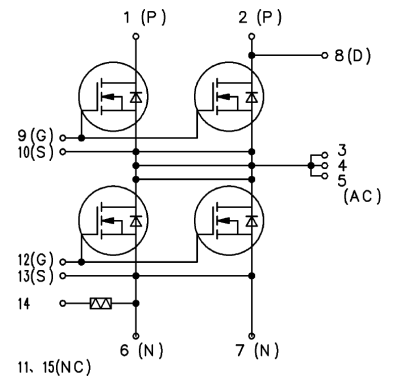
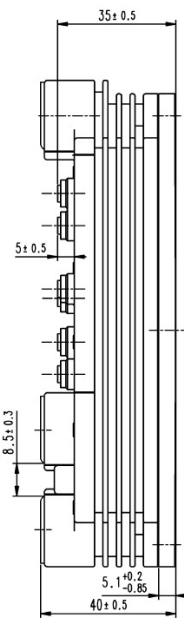
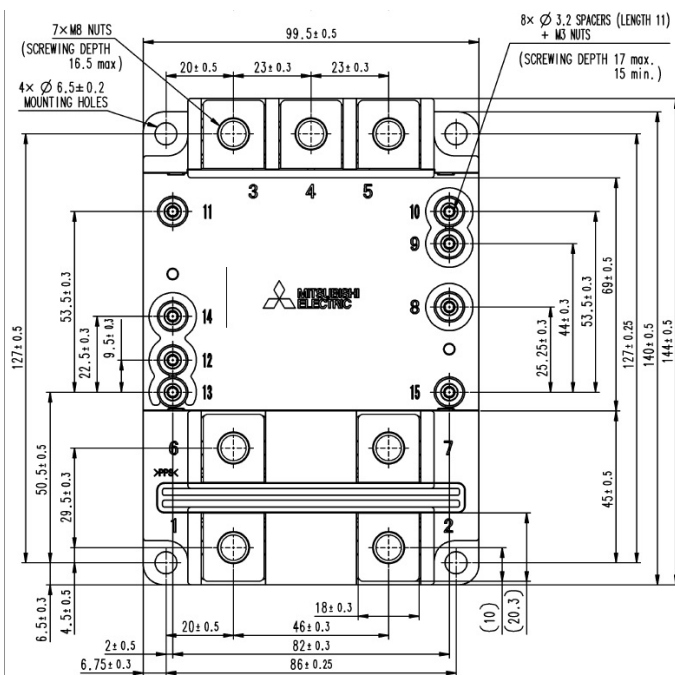

## CIRCUIT DIAGRAM

No.	Terminals
1, 2	DC+, D(P)
3, 4, 5	AC, S(P), D(N)
6, 7	DC-, S(N)
8	D(P)
9	G(P)
10	S(P)
11	NC
12	G(N)
13	S(N)
14	NTC
15	NC

< HV MOSFET MODULE >

**FMF800DC-66BEW**

**HIGH POWER SWITCHING USE**

**INSULATED TYPE**

2<sup>nd</sup> gen. HV MOSFET (High Voltage Metal Oxide Semiconductor Field Effect Transistor) Modules

**MAXIMUM RATINGS**

Item	Symbol	Condition	Ratings	Unit	
Drain-Source voltage, specified gate-source voltage	$V_{DSX}$	$V_{GS} = -7\text{ V}$	$T_J = -40\sim 175\text{ }^\circ\text{C}$	3300	V
Gate-Source voltage	$V_{GSS}$	$V_{DS} = 0\text{ V}$	$T_J = -40\sim 175\text{ }^\circ\text{C}$	$\pm 20$	V
Drain current	$I_D$	$V_{GS} = 17\text{ V}$ , $T_c = 87\text{ }^\circ\text{C}$ , AC terminal output current (Note 1)		800	A
Drain current	$I_{DP}$	Non repetitive pulse	$T_J = T_{op}$	1600	A
Reverse drain current (FWD forward current)	$I_S$	$V_{GS} = -7\text{ V}$ , $T_c = 85\text{ }^\circ\text{C}$ , AC terminal output current(Note 1)(Note 2)		800	A
Reverse drain current (FWD forward current)	$I_{SP}$	Non repetitive pulse(Note 2)	$T_J = T_{op}$	1600	A
Total power dissipation	$P_{tot}$	$T_c = 25\text{ }^\circ\text{C}$ , MOSFET part(Note 3)		6650	W
Isolation voltage	$V_{isol}$	Charge part to the baseplate RMS sinusoidal, 60Hz 1min		6000	$V_{rms}$
Partial discharge charge	$Q_{pd}$	Charged part to the baseplate RMS sinusoidal, 60 Hz 1min $V_1 = 3500\text{ V}$ , $V_2 = 2600\text{ V}$ (acc. to IEC 61287-1)		10	pC
Junction temperature	$T_J$	Maximum temperature range in off-state or on-state(non-switching)		-40~175	$^\circ\text{C}$
Case temperature	$T_c$	Maximum case temperature range in on-state		-40~150	$^\circ\text{C}$
Storage temperature	$T_{stg}$	Maximum case temperature range in off-state		-50~175	$^\circ\text{C}$
Operating junction temperature	$T_{jop}$	Maximum junction temperature range for switching operation		-40~175	$^\circ\text{C}$
Short-circuit withstand pulse duration	$t_{pSC}$	$V_{DD} = 2500\text{ V}$ , $V_{GS} = +17 / -7\text{ V}$ , $L_s = 40\text{ nH}$ , $V_{GS50\%}-V_{GS50\%}$	$T_J = T_{op}$	1.7	$\mu\text{s}$
Short circuit energy	$E_{SC}$	$V_{DD} = 2500\text{ V}$ , $F(t)$ weibull=1%	$T_J = T_{op}$	35	J
Non-repetitive surge forward current	$I_{FSM}$	$t_p = 10\text{ms}$ , $F(t)$ weibull=1%, Half sinewave	$T_J = 175\text{ }^\circ\text{C}$	5.9	kA
I <sup>2</sup> t value	$I^2t$	$t_p = 10\text{ms}$ , $F(t)$ weibull=1%, Half sinewave	$T_J = 175\text{ }^\circ\text{C}$	180	$\text{kA}^2\text{s}$

**ELECTRICAL CHARACTERISTICS**

Item	Symbol	Condition	Limits			Unit	
			Min.	Typ.	Max.		
Gate-source leakage current	$I_{GSS}$	$V_{DS} = 0\text{ V}$ , $V_{GS} = V_{GSS}$	$T_J = 25\text{ }^\circ\text{C}$	-2.0	-	2.0	$\mu\text{A}$
Drain-source cut-off current	$I_{DSX}$	$V_{DS} = V_{DSX}$ , $V_{GS} = -7\text{ V}$	$T_J = 25\text{ }^\circ\text{C}$	-	0.003	-	mA
			$T_J = 150\text{ }^\circ\text{C}$	-	0.050	-	mA
Gate-source threshold voltage	$V_{GS(th)}$	$V_{DS} = 10\text{ V}$ , $I_D = 80\text{mA}$	$T_J = 25\text{ }^\circ\text{C}$	1.60	2.10	2.60	V
			$T_J = 150\text{ }^\circ\text{C}$	-	1.50	-	V
Drain-source on resistance	$r_{DS(on)}$	$V_{DS} = V_{DS(on)}$ , $V_{GS} = 17\text{ V}$ , P-side(Terminal 8-10)	$T_J = 175\text{ }^\circ\text{C}$	0.90	1.45	1.90	V
			$T_J = 25\text{ }^\circ\text{C}$	-	2.00	-	$\text{m}\Omega$
			$T_J = 150\text{ }^\circ\text{C}$	-	4.31	-	$\text{m}\Omega$
Drain-source on resistance	$r_{DS(on)}$	$V_{DS} = V_{DS(on)}$ , $V_{GS} = 17\text{ V}$ , N-side(Terminal 10-13),(Note 5)	$T_J = 175\text{ }^\circ\text{C}$	-	5.00	6.06	$\text{m}\Omega$
			$T_J = 25\text{ }^\circ\text{C}$	-	2.25	-	$\text{m}\Omega$
			$T_J = 150\text{ }^\circ\text{C}$	-	4.63	-	$\text{m}\Omega$
Drain-source on-state voltage	$V_{DS(on)}$	$I_D = 800\text{ A}$ , $V_{GS} = 17\text{ V}$ , P-side(Terminal 8-10)(Note 4)	$T_J = 175\text{ }^\circ\text{C}$	-	5.38	6.44	$\text{m}\Omega$
			$T_J = 25\text{ }^\circ\text{C}$	-	1.60	-	V
			$T_J = 150\text{ }^\circ\text{C}$	-	3.45	-	V
Drain-source on-state voltage	$V_{DS(on)}$	$I_D = 800\text{ A}$ , $V_{GS} = 17\text{ V}$ , N-side(Terminal 10-13),(Note 4))(Note 5)	$T_J = 175\text{ }^\circ\text{C}$	-	4.00	4.85	V
			$T_J = 25\text{ }^\circ\text{C}$	-	1.80	-	V
			$T_J = 150\text{ }^\circ\text{C}$	-	3.70	-	V
			$T_J = 175\text{ }^\circ\text{C}$	-	4.30	5.15	V

< HV MOSFET MODULE >

**FMF800DC-66BEW**

HIGH POWER SWITCHING USE

INSULATED TYPE

2<sup>nd</sup> gen. HV MOSFET (High Voltage Metal Oxide Semiconductor Field Effect Transistor) Modules

**ELECTRICAL CHARACTERISTICS (continuation)**

Item	Symbol	Condition	Limits			Unit	
			Min.	Typ.	Max.		
Source-drain voltage	$V_{SD(on)}$	$I_S = 800\text{ A}, V_{GS} = 17\text{ V}, \text{P-side(Terminal 8-10)}(\text{Note 4})$	$T_J = 25\text{ }^\circ\text{C}$	-	1.45	-	V
			$T_J = 150\text{ }^\circ\text{C}$	-	3.25	-	V
			$T_J = 175\text{ }^\circ\text{C}$	-	3.80	4.40	V
		$I_S = 800\text{ A}, V_{GS} = 17\text{ V}, \text{N-side(Terminal 10-13)},(\text{Note 4)}(\text{Note 5})$	$T_J = 25\text{ }^\circ\text{C}$	-	1.65	-	V
			$T_J = 150\text{ }^\circ\text{C}$	-	3.50	-	V
			$T_J = 175\text{ }^\circ\text{C}$	-	4.10	4.70	V
Source-drain voltage	$V_{SD}$	$I_S = 800\text{ A}, V_{GS} = 0\text{ V}, \text{P-side(Terminal 8-10)}(\text{Note 4})$	$T_J = 25\text{ }^\circ\text{C}$	-	2.00	-	V
			$T_J = 150\text{ }^\circ\text{C}$	-	3.85	-	V
			$T_J = 175\text{ }^\circ\text{C}$	-	4.35	5.00	V
		$I_S = 800\text{ A}, V_{GS} = 0\text{ V}, \text{N-side(Terminal 10-13)},(\text{Note 4)}(\text{Note 5})$	$T_J = 25\text{ }^\circ\text{C}$	-	2.20	-	V
			$T_J = 150\text{ }^\circ\text{C}$	-	4.10	-	V
			$T_J = 175\text{ }^\circ\text{C}$	-	4.65	5.30	V
Source-drain voltage	$V_{SD(off)}$	$I_S = 800\text{ A}, V_{GS} = -7\text{ V}, \text{P-side(Terminal 8-10)}(\text{Note 4})$	$T_J = 25\text{ }^\circ\text{C}$	-	2.00	-	V
			$T_J = 150\text{ }^\circ\text{C}$	-	3.85	-	V
			$T_J = 175\text{ }^\circ\text{C}$	-	4.35	5.00	V
		$I_S = 800\text{ A}, V_{GS} = -7\text{ V}, \text{N-side(Terminal 10-13)},(\text{Note 4)}(\text{Note 5})$	$T_J = 25\text{ }^\circ\text{C}$	-	2.20	-	V
			$T_J = 150\text{ }^\circ\text{C}$	-	4.10	-	V
			$T_J = 175\text{ }^\circ\text{C}$	-	4.65	5.30	V
Input capacitance	$C_{iss}$	$V_{DS} = 10\text{ V}, V_{GS} = 0\text{ V}, f = 100\text{ kHz}, 1/2\text{ module}$	$T_J = 25\text{ }^\circ\text{C}$	-	110	-	nF
Output capacitance	$C_{oss}$	$V_{DS} = 10\text{ V}, V_{GS} = 0\text{ V}, f = 100\text{ kHz}, 1/2\text{ module}$	$T_J = 25\text{ }^\circ\text{C}$	-	70	-	nF
Reverse transfer capacitance	$C_{rss}$	$V_{DS} = 10\text{ V}, V_{GS} = 0\text{ V}, f = 100\text{ kHz}, 1/2\text{ module}$	$T_J = 25\text{ }^\circ\text{C}$	-	2.7	-	nF
Gate charge	$Q_G$	$V_{DD} = 1800\text{ V}, I_D = 800\text{ A}, V_{GS} = +17 / -7\text{ V}, 1/2\text{ module}$	$T_J = 25\text{ }^\circ\text{C}$	-	3.3	-	$\mu\text{C}$
Turn-on delay time	$t_{d(on)}$	$V_{DD} = 1800\text{ V}, I_D = 800\text{ A}, V_{GS} = +17 / -7\text{ V}, L_s = 40\text{ nH}$	$T_J = 175\text{ }^\circ\text{C}$	-	-	0.50	$\mu\text{s}$
Rise time	$t_r$	$V_{DD} = 1800\text{ V}, I_D = 800\text{ A}, V_{GS} = +17 / -7\text{ V}, L_s = 40\text{ nH}$	$T_J = 175\text{ }^\circ\text{C}$	-	-	0.30	$\mu\text{s}$
Turn-on (switching) energy per pulse 10% integral	$E_{on(10\%)}$	$V_{DD} = 1800\text{ V}, I_D = 800\text{ A}, V_{GS} = +17 / -7\text{ V}, L_s = 40\text{ nH}$ $R_{G(on)} = 1.5\ \Omega, R_{G(off)} = 1.5\ \Omega, \text{Inductive load}$	$T_J = 25\text{ }^\circ\text{C}$	-	0.26	-	J
			$T_J = 150\text{ }^\circ\text{C}$	-	0.22	-	J
			$T_J = 175\text{ }^\circ\text{C}$	-	0.22	-	J
Turn-on (switching) energy per pulse	$E_{on}$	$V_{DD} = 1800\text{ V}, I_D = 800\text{ A}, V_{GS} = +17 / -7\text{ V}, L_s = 40\text{ nH}$ $R_{G(on)} = 1.5\ \Omega, R_{G(off)} = 1.5\ \Omega, \text{Inductive load}$	$T_J = 25\text{ }^\circ\text{C}$	-	0.27	-	J
			$T_J = 150\text{ }^\circ\text{C}$	-	0.23	-	J
			$T_J = 175\text{ }^\circ\text{C}$	-	0.23	-	J
Total capacitive charge	$Q_C$	$V_{DD} = 1800\text{ V}, I_D = 800\text{ A}, V_{GS} = +17 / -7\text{ V}, L_s = 40\text{ nH}$ $R_{G(on)} = 1.5\ \Omega, R_{G(off)} = 1.5\ \Omega, \text{Inductive load}$	$T_J = 25\text{ }^\circ\text{C}$	-	10.7	-	$\mu\text{C}$
			$T_J = 150\text{ }^\circ\text{C}$	-	12.5	-	$\mu\text{C}$
			$T_J = 175\text{ }^\circ\text{C}$	-	12.5	-	$\mu\text{C}$
Diode turn-off energy (per pulse)	$E_{off\_Diode(10\%)}$	$V_{DD} = 1800\text{ V}, I_D = 800\text{ A}, V_{GS} = +17 / -7\text{ V}, L_s = 40\text{ nH}$ $R_{G(on)} = 1.5\ \Omega, R_{G(off)} = 1.5\ \Omega, \text{Inductive load}$	$T_J = 25\text{ }^\circ\text{C}$	-	0.004	-	J
			$T_J = 150\text{ }^\circ\text{C}$	-	0.005	-	J
			$T_J = 175\text{ }^\circ\text{C}$	-	0.005	-	J
Diode switching off energy of diode	$E_{off\_Diode}$	$V_{DD} = 1800\text{ V}, I_D = 800\text{ A}, V_{GS} = +17 / -7\text{ V}, L_s = 40\text{ nH}$ $R_{G(on)} = 1.5\ \Omega, R_{G(off)} = 1.5\ \Omega, \text{Inductive load}$	$T_J = 25\text{ }^\circ\text{C}$	-	0.004	-	J
			$T_J = 150\text{ }^\circ\text{C}$	-	0.006	-	J
			$T_J = 175\text{ }^\circ\text{C}$	-	0.006	-	J
Turn-off delay time	$t_{d(off)}$	$V_{DD} = 1800\text{ V}, I_D = 800\text{ A}, V_{GS} = +17 / -7\text{ V}, L_s = 40\text{ nH}$	$T_J = 175\text{ }^\circ\text{C}$	-	-	0.94	$\mu\text{s}$
Fall time	$t_f$	$V_{DD} = 1800\text{ V}, I_D = 800\text{ A}, V_{GS} = +17 / -7\text{ V}, L_s = 40\text{ nH}$	$T_J = 175\text{ }^\circ\text{C}$	-	-	0.40	$\mu\text{s}$
Turn-off (switching) energy per pulse 10% integral	$E_{off(10\%)}$	$V_{DD} = 1800\text{ V}, I_D = 800\text{ A}, V_{GS} = +17 / -7\text{ V}, L_s = 40\text{ nH}$ $R_{G(on)} = 1.5\ \Omega, R_{G(off)} = 1.5\ \Omega, \text{Inductive load}$	$T_J = 25\text{ }^\circ\text{C}$	-	0.10	-	J
			$T_J = 150\text{ }^\circ\text{C}$	-	0.11	-	J
			$T_J = 175\text{ }^\circ\text{C}$	-	0.11	-	J
Turn-off (switching) energy per pulse	$E_{off}$	$V_{DD} = 1800\text{ V}, I_D = 800\text{ A}, V_{GS} = +17 / -7\text{ V}, L_s = 40\text{ nH}$ $R_{G(on)} = 1.5\ \Omega, R_{G(off)} = 1.5\ \Omega, \text{Inductive load}$	$T_J = 25\text{ }^\circ\text{C}$	-	0.10	-	J
			$T_J = 150\text{ }^\circ\text{C}$	-	0.11	-	J
			$T_J = 175\text{ }^\circ\text{C}$	-	0.11	-	J

< HV MOSFET MODULE >

**FMF800DC-66BEW**

HIGH POWER SWITCHING USE

INSULATED TYPE 2<sup>nd</sup> gen. HV MOSFET (High Voltage Metal Oxide Semiconductor Field Effect Transistor) Modules

**THERMAL CHARACTERISTICS**

Item	Symbol	Conditions	Limits			Unit
			Min.	Typ.	Max.	
Thermal resistance junction to case	$R_{th(j-c)}$	Junction to Case, MOSFET + embeded SBD part, 1/2 module	-	-	22.5	K/kW
Contact thermal resistance case to heatsink	$R_{th(c-s)}$	Case to heat sink, $\lambda_{grease} = 1W/m^2K$ , $D_{(c-s)} = 70\mu m$ , 1/2 module	-	22.5	-	K/kW

**MECHANICAL CHARACTERISTICS**

Item	Symbol	Conditions	Limits			Unit
			Min.	Typ.	Max.	
Mounting torque	$M_t$	Main terminal screw M8 This is the case when installing the product on the bus bar	7.0	-	22.0	N·m
Mounting torque	$M_t$	Mounting screw M6	3.0	-	6.0	N·m
Mounting torque	$M_t$	Auxiliary terminals screw M3	0.4	-	0.8	N·m
Mass	m	-	-	0.8	-	kg
Comparative tracking index	CTI	-	600	-	-	-
Clearance distance in air	$d_a$	Between main terminal	8.0	-	-	mm
Creepage distance along surface	$d_s$	-	32.0	-	-	mm
Internal inductance, D-S	$L_{PDS}$	Between DC+ and DC-(terminal1,2-6,7)	-	15	-	nH
	$L_{PDS}$	Between DC+ and AC (terminal1,2-3,4,5)	-	43	-	nH
	$L_{PDS}$	Between AC and DC-(terminal3,4,5-6,7)	-	43	-	nH
Internal lead resistance, DD'-SS'	$R_{DD+SS'}$	$T_C=25^\circ C$ , Between DC+ and DC-(terminal1,2-6,7)	-	0.46	-	mΩ
	$R_{DD+SS'}$	$T_C=25^\circ C$ , Between DC+ and AC(terminal1,2-3,4,5)	-	0.22	-	mΩ
	$R_{DD+SS'}$	$T_C=25^\circ C$ , Between AC and DC-(terminal3,4,5-6,7)	-	0.33	-	mΩ
Zero-power resistance	$R_{25}$	$T_C=25^\circ C$	4.65	5.00	5.35	kΩ
B-constant	$B_{(25/50)}$	Approximate by equation,(Note 6)	-	3375	-	K

Note 1. Control Case Temperature ( $T_c$ ) so that the junction temperature ( $T_j$ ) does not exceed the maximum rating.

Note 2. The symbols represent characteristics of the anti-parallel, source to drain free-wheel diode (FWDi).

Note 3. Junction temperature ( $T_j$ ) should not exceed  $T_{jmax}$  rating.

Note 4. Pulse width and repetition rate should be such as to cause negligible temperature rise.

Note 5. N-side characteristic value includes wiring resistance between P-side source potential and N-side drain potential.

(P-side characteristic value corresponds to chip characteristics).

Note 6.  $B_{(25/50)} = \ln \left( \frac{R_{25}}{R_{50}} \right) / \left( \frac{1}{T_{25}} - \frac{1}{T_{50}} \right)$

$R_{25}$ : resistance at absolute temperature  $T_{25}$  [K];  $T_{25} = 25[^\circ C] + 273.15 = 298.15[K]$

$R_{50}$ : resistance at absolute temperature  $T_{50}$  [K];  $T_{50} = 50[^\circ C] + 273.15 = 323.15[K]$

Products falling under the subject item No. 2 (41) 3 of Appended Table 1 of the Export Trade Control Order.

# FMF800DC-66BEW

HIGH POWER SWITCHING USE

INSULATED TYPE

2<sup>nd</sup> gen. HV MOSFET (High Voltage Metal Oxide Semiconductor Field Effect Transistor) Modules

## PERFORMANCE CURVES

**OUTPUT CHARACTERISTICS (TYPICAL)**

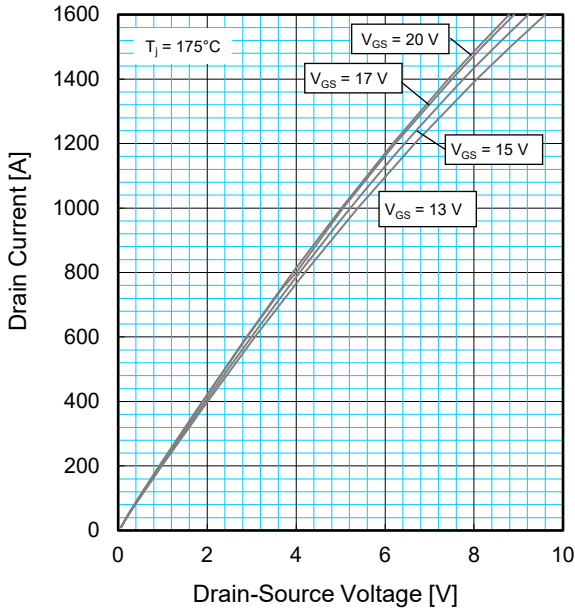

**TRANSFER CHARACTERISTICS (TYPICAL)**

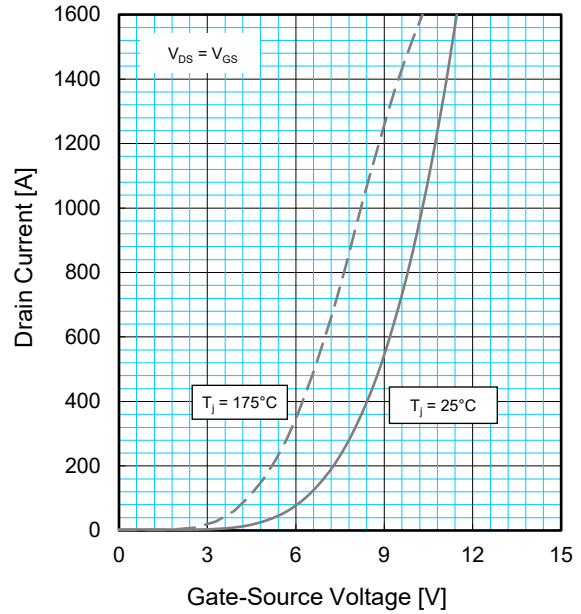

**DRAIN-SOURCE ON VOLTAGE CHARACTERISTICS (TYPICAL)**

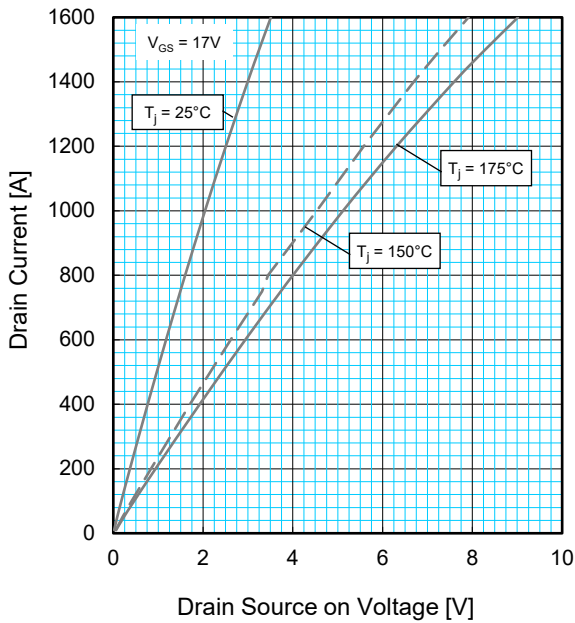

**FREE-WHEEL DIODE FORWARD CHARACTERISTICS (TYPICAL)**

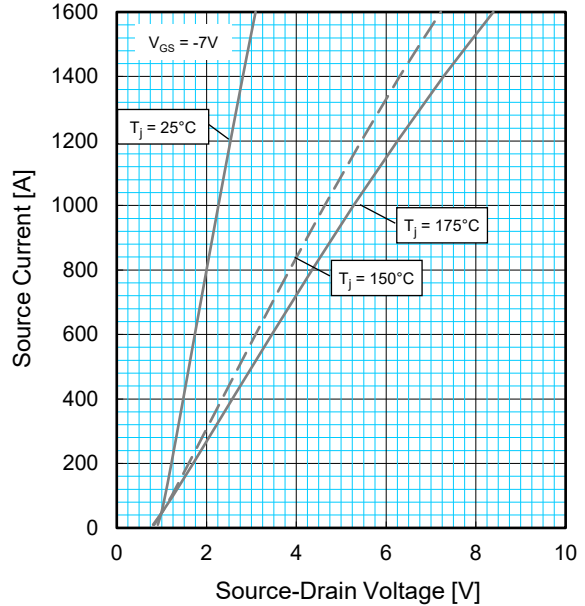

# FMF800DC-66BEW

HIGH POWER SWITCHING USE

INSULATED TYPE 2<sup>nd</sup> gen. HV MOSFET (High Voltage Metal Oxide Semiconductor Field Effect Transistor) Modules

## PERFORMANCE CURVES

**FREE-WHEEL DIODE FORWARD CHARACTERISTICS (TYPICAL)**

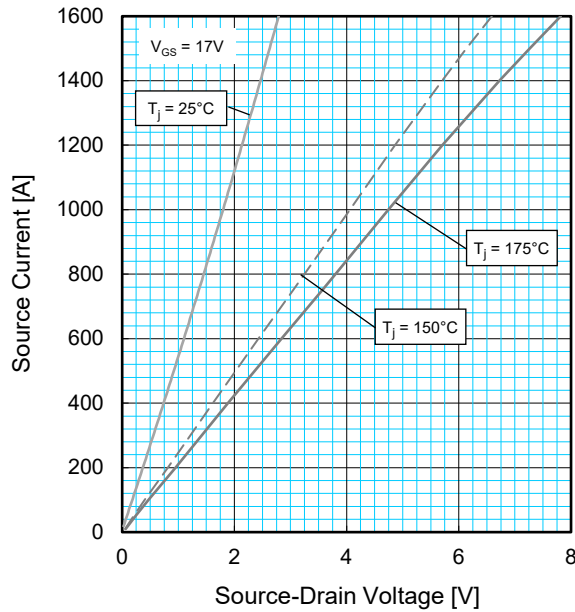

**CAPACITANCE CHARACTERISTICS (TYPICAL)**

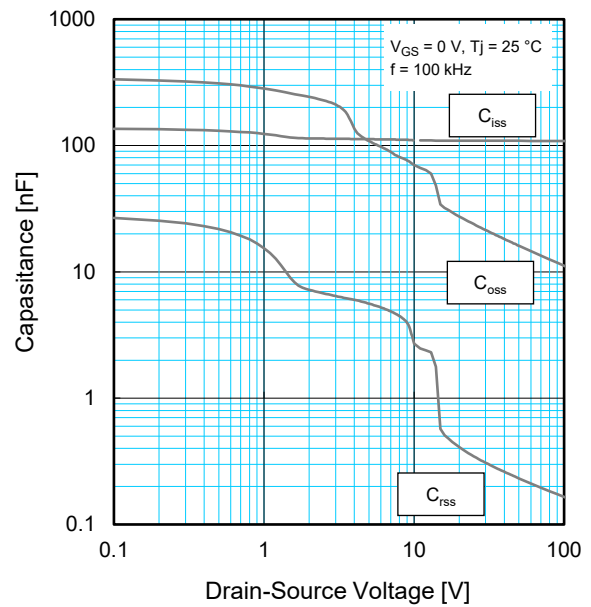

**GATE CHARGE CHARACTERISTICS (TYPICAL)**

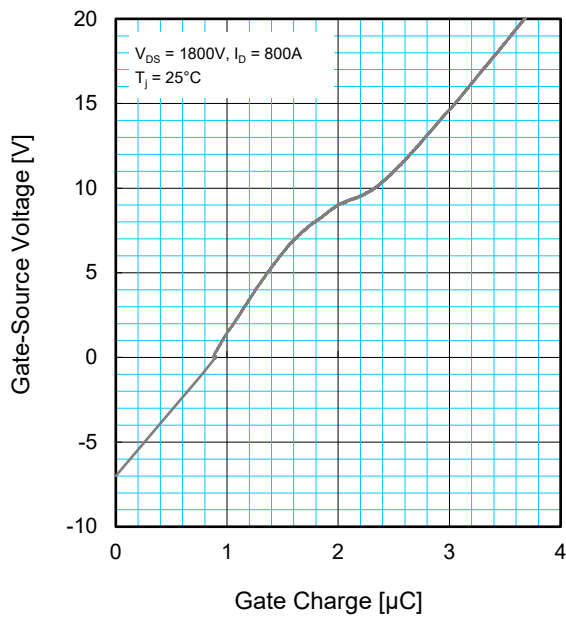

**HALF-BRIDGE SWITCHING ENERGY CHARACTERISTICS (TYPICAL)**

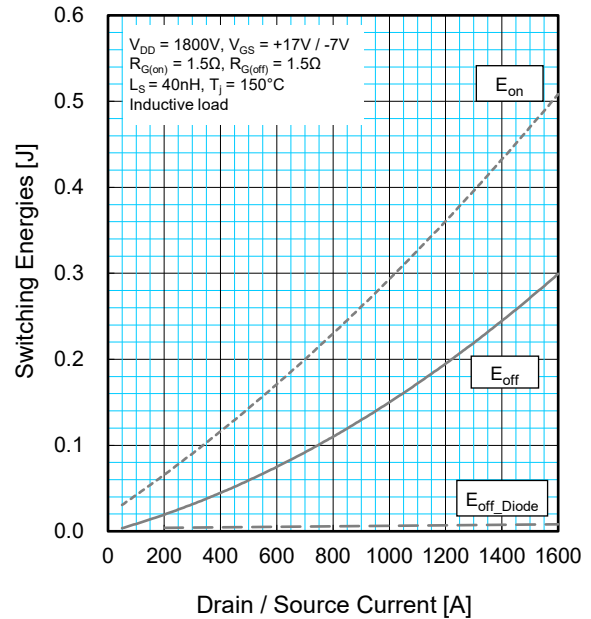

# FMF800DC-66BEW

HIGH POWER SWITCHING USE

INSULATED TYPE

2<sup>nd</sup> gen. HV MOSFET (High Voltage Metal Oxide Semiconductor Field Effect Transistor) Modules

## PERFORMANCE CURVES

**HALF-BRIDGE SWITCHING ENERGY CHARACTERISTICS (TYPICAL)**

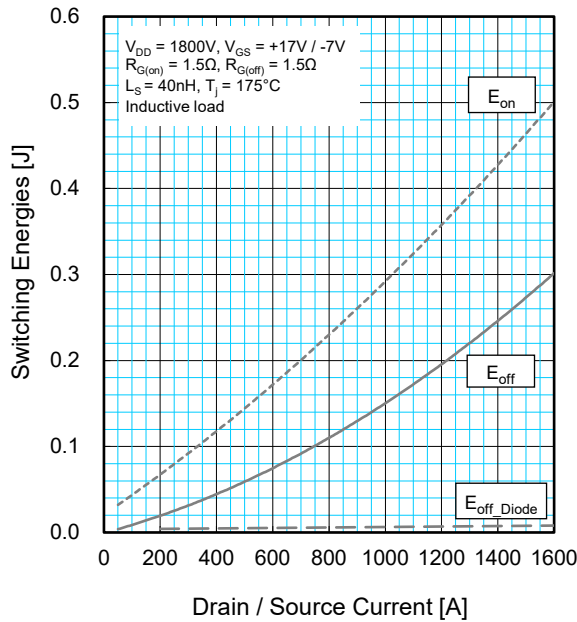

**HALF-BRIDGE SWITCHING ENERGY CHARACTERISTICS (TYPICAL)**

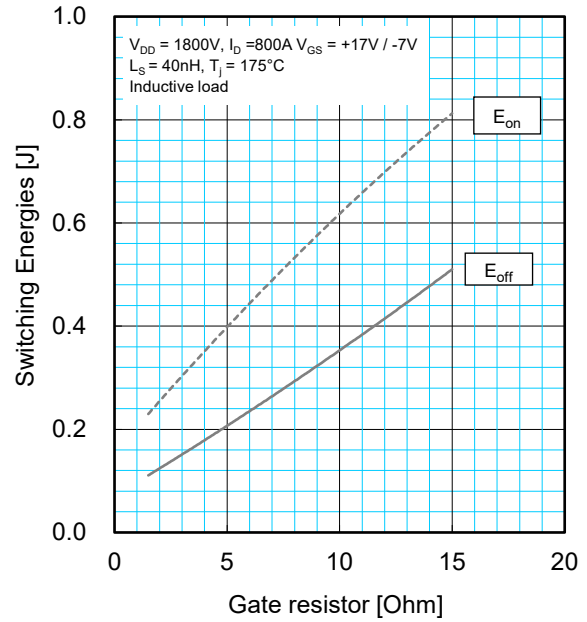

**REVERSE BIAS SAFE OPERATING AREA (RBSOA)**

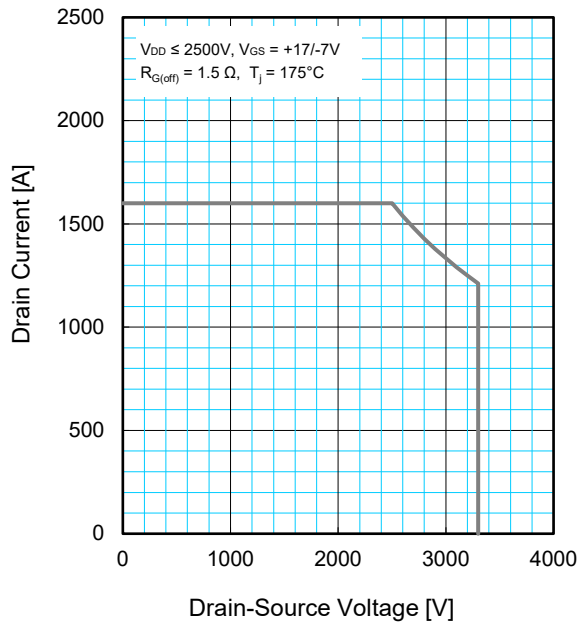

**SHORT CIRCUIT SAFE OPERATING AREA (SCSOA)**

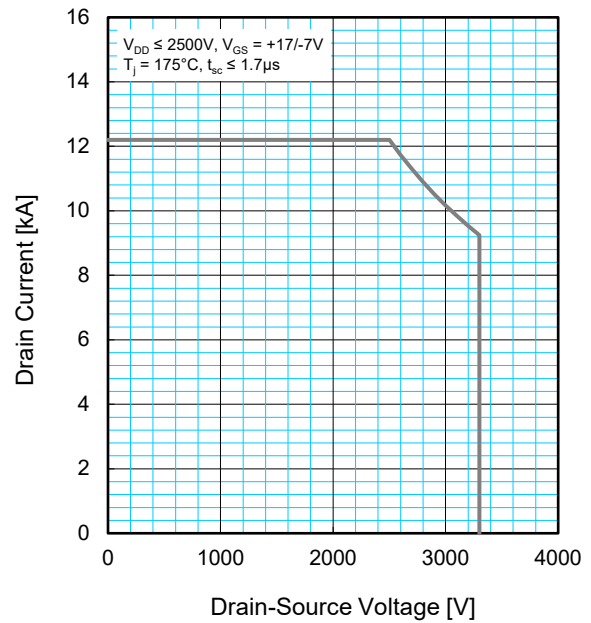

# FMF800DC-66BEW

HIGH POWER SWITCHING USE

INSULATED TYPE 2<sup>nd</sup> gen. HV MOSFET (High Voltage Metal Oxide Semiconductor Field Effect Transistor) Modules

## PERFORMANCE CURVES

### TRANSIENT THERMAL IMPEDANCE CHARACTERISTICS

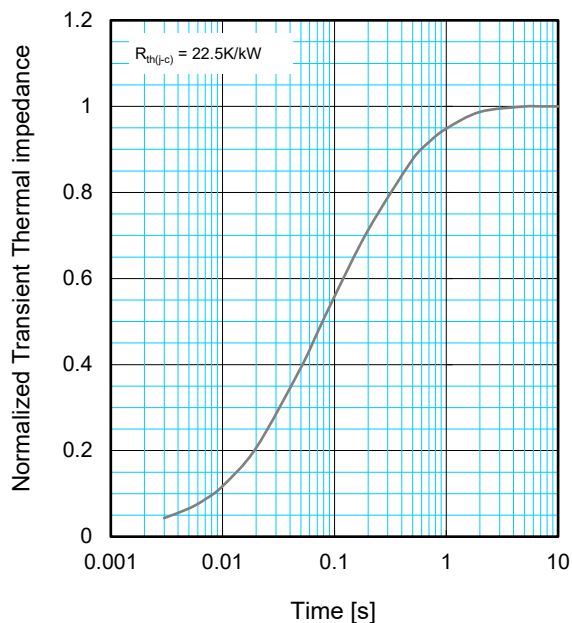

$$Z_{th(j-c)}(t) = \sum_{i=1}^n R_i \left\{ 1 - \exp\left(-\frac{t}{\tau_i}\right) \right\}$$

	1	2	3	4
$R_i / R_{th}$ :	0.0078	0.1975	0.3553	0.4393
$\tau_i$ [sec.] :	0.0001	0.7324	0.0381	0.1698

### NTC THERMISTOR TEMPERATURE CHARACTERISTICS (TYPICAL)

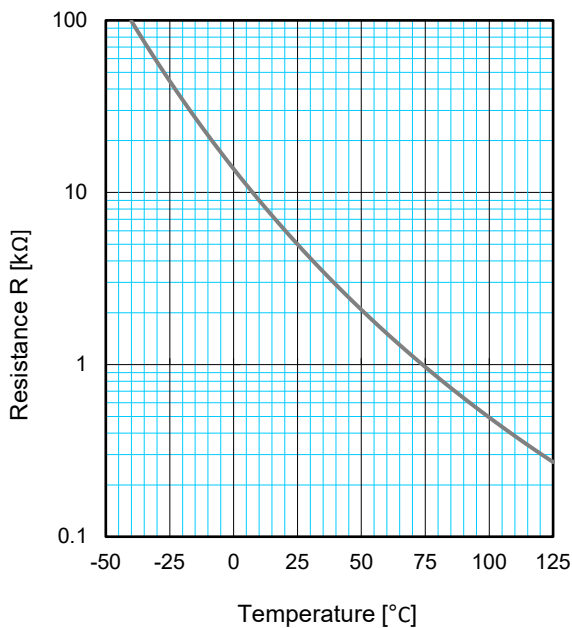



### **Important Notice**

The information contained in this datasheet shall in no event be regarded as a guarantee of conditions or characteristics. This product has to be used within its specified maximum ratings, and is subject to customer's compliance with any applicable legal requirement, norms and standards.

Except as otherwise explicitly approved by Mitsubishi Electric Corporation in a written document signed by authorized representatives of Mitsubishi Electric Corporation, our products may not be used in any applications where a failure of the product or any consequences of the use thereof can reasonably be expected to result in personal injury.

In usage of power semiconductor, there is always the possibility that trouble may occur with them by the reliability lifetime such as Power Cycle, Thermal Cycle or others, or when used under special circumstances (e.g. condensation, high humidity, dusty, salty, highlands, environment with lots of organic matter / corrosive gas / explosive gas, or situations which terminals of semiconductor products receive strong mechanical stress). Therefore, please pay sufficient attention to such circumstances. Further, depending on the technical requirements, our semiconductor products may contain environmental regulation substances, etc. If there is necessity of detailed confirmation, please contact our nearest sales branch or distributor.

The contents or data contained in this datasheet are exclusively intended for technically trained staff. Customer's technical departments should take responsibility to evaluate the suitability of Mitsubishi Electric Corporation product for the intended application and the completeness of the product data with respect to such application. In the customer's research and development, please evaluate it not only with a single semiconductor product but also in the entire system, and judge whether it's applicable. As required, pay close attention to the safety design by installing appropriate fuse or circuit breaker between a power supply and semiconductor products to prevent secondary damage. Please also pay attention to the application note and the related technical information.

### **Keep safety first in your circuit designs!**

Mitsubishi Electric Corporation puts the maximum effort into making semiconductor products better and more reliable, but there is always the possibility that trouble may occur with them. Trouble with semiconductors may lead to personal injury, fire or property damage. Remember to give due consideration to safety when making your circuit designs, with appropriate measures such as (i) placement of substitutive, auxiliary circuits, (ii) use of non-flammable material or (iii) prevention against any malfunction or mishap.

### **Notes regarding these materials**

- These materials are intended as a reference to assist our customers in the selection of the Mitsubishi Electric Semiconductor product best suited to the customer's application; they do not convey any license under any intellectual property rights, or any other rights, belonging to Mitsubishi Electric Corporation or a third party.
- Mitsubishi Electric Corporation assumes no responsibility for any damage, or infringement of any third-party's rights, originating in the use of any product data, diagrams, charts, programs, algorithms, or circuit application examples contained in these materials.
- All information contained in these materials, including product data, diagrams, charts, programs and algorithms represents information on products at the time of publication of these materials, and are subject to change by Mitsubishi Electric Corporation without notice due to product improvements or other reasons. It is therefore recommended that customers contact Mitsubishi Electric Corporation or an authorized Mitsubishi Electric Semiconductor product distributor for the latest product information before purchasing a product listed herein.  
The information described here may contain technical inaccuracies or typographical errors. Mitsubishi Electric Corporation assumes no responsibility for any damage, liability, or other loss rising from these inaccuracies or errors.  
Please also pay attention to information published by Mitsubishi Electric Corporation by various means, including the Mitsubishi Electric Semiconductor home page (<https://www.MitsubishiElectric.com/semiconductors/>).
- When using any or all of the information contained in these materials, including product data, diagrams, charts, programs, and algorithms, please be sure to evaluate all information as a total system before making a final decision on the applicability of the information and products. Mitsubishi Electric Corporation assumes no responsibility for any damage, liability or other loss resulting from the information contained herein.
- Mitsubishi Electric Corporation semiconductors are not designed or manufactured for use in a device or system that is used under circumstances in which human life is potentially at stake. Please contact Mitsubishi Electric Corporation or an authorized Mitsubishi Electric Semiconductor product distributor when considering the use of a product contained herein for any specific purposes, such as apparatus or systems for transportation, vehicular, medical, aerospace, nuclear, or undersea repeater use.
- The prior written approval of Mitsubishi Electric Corporation is necessary to reprint or reproduce in whole or in part these materials.
- If these products or technologies are subject to the Japanese export control restrictions, they must be exported under a license from the Japanese government and cannot be imported into a country other than the approved destination.  
Any diversion or re-export contrary to the export control laws and regulations of Japan and/or the country of destination is prohibited.
- Please contact Mitsubishi Electric Corporation or an authorized Mitsubishi Electric Semiconductor product distributor for further details on these materials or the products contained therein.